

POLICY & STANDARDS

PERMIT WORK WITHIN COUNTY RIGHT OF WAY



ULSTER COUNTY DEPARTMENT OF PUBLIC WORKS

*317 Shamrock Lane
Kingston, NY 12401*

TEL.(845)340-3100 FAX(845)340-3113

ulstercountyny.gov

TABLE OF CONTENTS

	<u>PAGE</u>
INTRODUCTION ~ ~ ~ ~ ~	3
COUNTY ROAD INDEX ~ ~ ~ ~ ~	4
GOVERNING STATUTE ~ ~ ~ ~ ~	5-7
SECTION I. Procedure For Obtaining Permits ~ ~ ~ ~ ~	8-9
A. Application ~ ~ ~ ~ ~	8
B. Time Limitations ~ ~ ~ ~ ~	9
C. Inspection ~ ~ ~ ~ ~	9
SECTION II. General Conditions	
A. General ~ ~ ~ ~ ~	10-11
SECTION III. Design and Construction Standards ~ ~ ~ ~ ~	12-21
A. Accesses, General ~ ~ ~ ~ ~	12-13
B. Residential Access ~ ~ ~ ~ ~	14
C. Site Plan/Subdivision ~ ~ ~ ~ ~	14-17
D. New Streets and Commercial Access ~ ~ ~ ~ ~	17-18
E. Utilities And Other Improvements ~ ~ ~ ~ ~	18-21
SECTION IV. Definitions ~ ~ ~ ~ ~	22
SECTION V. Special Conditions ~ ~ ~ ~ ~	22-23
SECTION VI. Soil Erosion and Sediment Control ~ ~ ~ ~ ~	23
SECTION VII. Forms And Sketches ~ ~ ~ ~ ~	23
Permit For Work On A County Road ~ ~ ~ ~ ~	24-25
Notification Procedure Prior To Starting Work ~ ~ ~ ~ ~	26
Schedule of Fees For Permits – Work Within County ROW ~ ~	27
Location Request Information Sheet ~ ~ ~ ~ ~	28
Summary of Orange County Insurance Requirements ~ ~ ~ ~ ~	29
Certificate Of Liability Insurance ~ ~ ~ ~ ~	30
Workers Compensation Requirements ~ ~ ~ ~ ~	31
Typical Sketches ~ ~ ~ ~ ~	34-43

INTRODUCTION

This publication sets forth the policy and standards of the Ulster County Department of Public Works for granting access to and the performing of any work on or within County road corridors, and indicates the requirements for the establishment and construction of such accesses and performance of all work.

The following requirements are applicable to all commercial and industrial establishments, service areas, private residences, subdivisions and utilities having access to and/or through the right of way of a county road, with respect to drainage, geometric design, type and quality of workmanship, material used, and work performed within county road limits. The statutory right of way of a county road with respect to maintenance purposes is as defined on county road maps.

Any person, firm, corporation or municipality or governmental entities desiring to gain access to a county road or perform any work within the road limits shall do so only through a permit that so adheres to the standards set forth in this manual, and shall make application to secure such a permit from the Permit Section of the Engineering Division of the Ulster County Department of Public Works, 317 Shamrock Lane, Kingston, NY 12401, Telephone: (845) 340-3100, Fax: (845) 340-3113, as mandated by Article 6, Section 136 of the New York State Highway Law.

Prepared by the Division of Engineering
Ulster County Department of Public Works

REVISED: MAY 2019

Compilation of County Roads where a validated permit shall be acquired prior to any site preparation or construction, including subdivisions, site plans, utility connections, or other activity affecting the County Road System.

COUNTY ROAD INDEX

1-141 Frost Valley Road (West Branch Road)	67 Pancake Hollow Road (Centerville-Bailey Gap)	114 Ohayo Mountain Road (Woodstock-Glenford-Ohayo)
2 Sundown Road (County Line-Sundown Road)	68 Milton Turnpike	116 Crescent Avenue
4 Union Center Road (Ulster Park-St Remy)	69 Plattekill Road (Marlborough-Middlehope)	117 New Paltz-Minnewaska
6 Bruynswick Road (Bruynswick-Benton's Cors Rd)	70 Hoagerburgh Road	118 Glasco Turnpike (Schoentags-Glasco Tpk)
7A Dry Brook Road	72 Cottekill Road (Binnewater-Cottekill Rd)	119 Dock Street (Milton-Milton Landing)
8 Hurley Mtn Road Wynkoop Lane	73 Creek Locks Road (Bloomington-Creek Locks)	120 Harry Wells Road (Blue Mtn-Quarryville)
8A Spillway Road	74 Bruynswick Road (Guilfor Church-Bentons Cors)	122 Wallkill Avenue (Wallkill-Newburgh)
10 Sawkill Road	75 Sawkill-Zena Road	123 Lucas Turnpike
11 Eltings Corners Rd, South St	76 Samsonville-Kerhonkson Rd	124 Ulster Ave
12 Cooler Rd, Station Rd	77 Main Street (Gardiner-Kerhonkson)	127 McKinstry Road (Jansen-Herrick-McKinstry Rd)
13 Stone Ridge-Atwood State Route 213	78 Briggs Highway	128 Main Street Napanoch (Napanoch Vill.-Institution Rd)
14 Hurley Mountain Road	79 Guilfor Cors-Mud Tavern	129 Sand Hill-Gardiner
16 Milton Turnpike	80 Spring Glen Road	130 Stony Hollow-Route 28A
17 Lattintown Road, Western Ave	81 River Road	131 Glasco Turnpike (Byrdcliff Road)
18A Springtown Road	82 Old Post Road	132 Hurley Mountain Road
18B South Ohioville Road	83 Morgan Hill Road	135 West Saugerties-Woodstock Rd
20 Atwood Road, Olive Bridge	84 Riverside Road (Black Cree-Riverside Rd)	136 Glasco Turnpike (Shultis Cors-Glasco Tpk)
22 Clintondale Concrete	85 Lattintown Road (Swartz Br-Wygant-Lattintown)	137 Stony Hollow (Waughonk Road)
23 Clintondale Road	87 Mountain Road (Ashokan-DuBoice-Mtn Rd)	139 West Shokan-Peekamoose
23A Forest Road	88 Rosendale-Cottekill Road	140 Breakneck Road (Breakneck-East Rd-Plattekill)
24 Gravel Road Orchard Drive	89 Malden Turnpike (Kaufman Cors-Malden)	141 West Branch Road
24A Browns Corners Road Tuckers Corners Road	90 Sawkill-Ruby Road (Sawkill-McGuires Corners)	142 Glenford-Yankeetown Pond
25 Plattekill-Ardonia Road	91 Wittenberg-Mt Tremper	144 Fosler Road (Tuckers Cors-Fosler Rd)
29 Pataukunk Road	92 Big Indian-Oliverea-Slide Mtn	145 Gelli Curci Rd & Todd Mtn Road (Highmount-Mapledal-Gelli Curci)
29A Alligerville Road Kyserike Road	94 Hurley-DeWitt Mills-Fortner- Zandhoek Road	146 Creek Locks Road (Eddyville-Creek Locks)
31 Old Kings Highway	95 Mountain Rest Road	147 Kallops Cors-Breezy Hill Rd
32 Kings Highway	96 Sylva-New Hurley Road	148 Long Lane
33 Kings Highway	97 Fishcreek Road	149 Milk Road
34 Glasco Turnpike	98 Burlingham Road (Ulsterville Road)	150 Shandaken-Big Indian
39B Brunswick-New Prospect Rd	99 Ulster Landing Road	151 Hurley Avenue Extension
41 Leggs Mill Road	101 Yagerville Road (Sundown-Montela-Yagerville)	152 Kukuk Lane
42 Sawlill Road	102 Turnwood Road (Lew Beach-Turnwood Rd)	153 Eddyville-Mountain Road
44 Greenfield Road	103 Hallihans Hill Road	154 South Putt Cors, North Putt Cors Horsenden Road
46 Bearsville-Wittenberg Road	104 Cragmoor Road	155 Main Street, Bridge Street
47A Rock City Road	106 Krumville Road (Samsonville-Krumville Rd)	156 Clove Road
50 Lucas Turnpike	108 Chapel Hill Road	157 Boices Lane, Enterprise Drive
51 West Saugerties Road	109D Tillson Lake-Decker Road	158 Jansen Road
52 West Hurley-Zena Road	109A Awosting Road	159 Old New Paltz Road (Ols Rte 299, Highland-Lloyd)
53 Samsonville Road	109I Oregon Trail Road	160 Old Rte 28 Mt Tremper-Phoenicia
55 Orchar Road-Millton Cross Rd	111 Granite Road (Accord-Granite Road)	161 Frank Sottile Boulevard
56 Ulster Heights Road	112 Plains Road	162 Miron Lane
57 Port Ewen-New Salem Street	113 Eltings Road (Tillson-Eltings Road)	
58 Lucas Turnpike (High Falls - Accord)		
59 Binnewater Road		
60 East Kingston-Ulster Landing		
61 New Paltz-Cty Home, Libertyville		
63 Kripplebush-Davis Corners Krumville Road		
64 Blue Mountain-Saxton		
65 Eddyville-DeWitt Mills		
66 Maverick Road		

Governing Statute

The Highway Law, Article 5, Section 102 of the Consolidated Laws of New York, prescribes certain powers and duties of the County Superintendent of Highways or the Commissioner of Public Works. Among these duties is the general supervision of the highways and bridges, which are constructed, improved or maintained in whole or in part within the county.

In this regard, attention is directed to Article 6, Section 136 of the Highway Law, which provides as follows:

Section 136. Permits for work within the county road right of way

1. Except in connection with the construction, reconstruction, maintenance or improvement of a county road or operations of a corporation pursuant to the provisions of section twenty-seven of the transportation corporations law or section twenty-one, eighty-nine, ninety-one, ninety-three, ninety-three-a and ninety-three-b of the railroad law, no person, firm, corporation or municipality shall construct or improve, within the county road right of way an entrance or connection to such road, or construct within the county road right of way any works, structure or obstruction, or any overhead or underground crossing thereof, or lay or maintain therein underground wires or conduits or drainage, sewer or water pipes, except in accordance with the terms and conditions of a work permit issued by the county superintendent or his duly designated agent, notwithstanding any consent or franchise granted by any town superintendent, or by any municipal authority. Any municipal corporation may enter upon any county road for the purpose of widening the pavement or for any other purpose authorized by this section, but only after securing a permit as provided herein. Notwithstanding the limitations in any general or special law, every municipal corporation shall have and is hereby given authority to deposit with the county superintendent such a sum of money or a security bond as may be required as a condition precedent to the granting of the permit provided in this section.
2. The county superintendent shall establish regulations governing the issuance of highway work permits, including the fees to be charged thereof, a system of deposits of money or bonds guaranteeing the performance of the work and requirements of insurance to protect the interests of the county during performance of the work pursuant to a highway work permit. With respect to driveway entrance permits, the regulations shall take into consideration the prospective character of the development, the traffic which will be generated by the facility within the reasonably foreseeable future, the design and frequency of access to the facility, the effect of the facility upon drainage as related to existing drainage systems, the extent to which such facility may impair the safety and traffic carrying capacity of the existing county road and any proposed improvement thereto within the reasonably foreseeable future, and any standards governing access, nonaccess or limited access which have been established by the county superintendent.
3. Upon the completion of the work within the county road right of way, authorized by the work permit, the person, firm, corporation, municipality, and his or its successors in interest, shall be responsible for the maintenance and repair of such work or portion of such work as set forth within the terms and conditions of the work permit.

4. An advertising sign, display or devise, or any part thereof, erected in violation of this section shall be removed from the county road right of way by the owner or party responsible for its erection. The county superintendent shall make a demand by mail, to the last known address of the owner, apparent owner or party responsible for the erection of such advertising sign, display or device, for its removal and, if it is not removed within twenty (20) days from the date of the mailing of such demand, the county superintendent may remove any such advertising sign, display or devise, or any part thereof, from the county road right of way.
5. The term “county road right of way” shall, for the purposes of this section, mean the entire width between the boundary line of all property which has been appropriated by the county for county road purposes, all property over which the county superintendent or his predecessors has assumed jurisdiction for county road purposes, all property over which the county superintendent has assumed jurisdiction during the period of construction, reconstruction or improvement and all property which has become part of the county road system through dedication or use.
6. Any person, firm or corporation violating the section shall be liable to a fine of not less than twenty-five dollars nor more than one thousand dollars for each day of violation, to be recovered by the county superintendent and paid to the county treasury to the credit of the county road fund created under this article for the construction, reconstruction and maintenance of county roads on the county road system in accordance with the provisions of this article, and may also be removed therefrom as a trespasser by the county superintendent upon petition to the county court of the county or to the supreme court of the state.

NEW YORK INDUSTRIAL CODE

Prior to any digging, drilling or blasting within the County Road Corridor the permittee shall contact the Underground Facilities Protective Organization at 811, at 1-800-962-7962 or at www.digsafelynewyork.com at least two days prior to any work.

Ulster County Department of Public Works
Policy & Standards for Access to and Work Performed
On or Along County Roads

SECTION I

Procedure for Obtaining Permits:

Any Person, Firm, Corporation or Municipality desiring to construct any access from a County Road or affecting the County Road System shall, before beginning any work, apply for and secure a Work Permit from the Ulster County Department of Public Works and upon issuance of such permit, must comply with the terms thereof.

If a property owner, lessee or agent fails to comply with the terms of a work permit or fails to obtain a work permit, the Ulster County Department of Public Works shall exercise its powers under Section 136 of the Highway Law to halt the activity for which a work permit is required until adequate corrections have been made. Cost incurred by the Ulster County Department of Public Works or its agent to correct unacceptable conditions caused by said failures shall be borne by the permittee undertaking the activity under applicable provisions of Civil Law.

A. Application:

Prior to commencing construction of any access, site preparation, related improvements or performing any work affecting the County Road System, the prospective permittee shall submit to the Department two copies of plans which shall clearly indicate the character and extent of the work and the manner of performing the work in conformance with the sample detail and specifications hereby furnished within a completed application form and fee as per schedule. Upon approval of the plans the Department shall notify the permittee of the performance deposit, and inspection fee which is to be submitted in the form of certified checks or bank checks made payable to the Ulster County Commissioner of Finance along with the providing of a Certificate of the Contractors Liability Insurance naming the Ulster County Department of Public Works as a Certificate Holder including additional insured form naming the County of Ulster as additional insured. Coverage shall be maintained in such a manner and in such case as the Commissioner of Public Works may require or \$500,000 combined or \$1,000,000 above combined as directed. Upon approval and submission of the above, a permit will be issued stipulating the conditions under which such work shall be performed. The Ulster County Department of Public Works reserves the right to revoke or cancel the permit at any time should the applicant fail to comply with terms and conditions herein prescribed. Issuing of a permit will be subject to conditions such as but not limited to the following.

1. The location, design and construction shall meet the general conditions and design standards specified by the Department. Necessary provisions for drainage, soil erosion control measures, pavement types and thickness, sight distance requirements and other specific construction details must be acceptable to the Department.
2. All general and specific conditions as stated on the permit shall be complied with.

3. The permittee will submit a certified check or bank check for a Performance Deposit along with a certified check or bank check for the Application Fee and Inspection Fee payable to the Ulster County Commissioner of Finance in the amounts specified by the Ulster County Department of Public Works, Division of Engineering to guarantee satisfactory completion of the authorized work. The Performance Deposit will be refunded at such time as the work has been completed and inspected to the satisfaction of the Ulster County Department of Public Works. The amount of the Performance Deposit and Inspection fees shall be consistent with the scope and magnitude of the work involved. The permittee shall also reimburse the Department for the cost for an on the job inspector whenever deemed necessary by the Department. Any expense incurred by the Department due to emergency maintenance or correction work that is the responsibility of the permittee, shall be reimbursed prior to final inspection and permit closure.
4. Comprehensive Liability Insurance shall be provided in the amounts and coverage as previously described, and proof of Workers Compensation and Disability Benefits coverage, and said insurance shall be continuously maintained during the life of the permit.

B. Time Limitations

1. The Ulster County Department of Public Works shall be notified of work commencement in the terms of the permit conditions requested. In all cases the Division of Engineering Permit Agent shall be notified at least 48 hours in advance of any work within the County Road Right of Way in order that the inspection of any such work can be made. The permit shall be issued for a length of One (1) year. In the event that a project runs for longer than one year, within 15 days of the expiration of the current permit, the permittee shall apply for an extension of the permit and pay the appropriate application fee.
2. Except when specifically approved by the Ulster County Department of Public Works, work will not be permitted within the right of way limits of any County Road between November 15th and March 15th of the succeeding year.
3. If work has not been completed by November 15th the site shall be left in a condition specified by the Department until March 15th of the succeeding year, when work may be resumed.
4. Emergency utility repairs may be made upon issuance of a Highway Work permit and approved temporary restoration procedures implemented. It will be the responsibility of the permittee to complete the final restoration as soon as weather permits. In no case shall the Department close the permit until final restoration work has been completed.

C. Inspection

1. Inspection fees include a certain number of inspections of the work as described in the Schedule of Fees for Permits. If additional site inspections are required by the UCDPW, additional fees per inspection may be assessed and charged at the direction of the Commissioner of Public Works or his representative. Fees for additional inspections shall be deducted from the Performance Deposit prior to permit close-out and return of securities.

SECTION II

GENERAL CONDITIONS

The conditions described in this section will be included in permits whenever applicable and deemed necessary by the Department.

A. GENERAL

1. The property owner or permittee having access to a County Road is fully responsible for the maintenance of his driveway, including the portion from the road right of way line to the road pavement edge or curb line for the effective period of the permit. This maintenance responsibility includes the removal of obstructions to visibility, snow and ice, and keeping the portion within the highway right of way in a safe condition. Where owner of a commercial property or permittee is required to construct acceleration, deceleration or turning lanes on a County Road, the Ulster County Department of Public Works may, in the interest of public convenience, provide routine maintenance responsibility of these lanes when deemed necessary.
2. The property owner is also responsible for the maintenance of an unobstructed sight distance, ditches, pipes, catch basins, grates and other drainage structures constructed in connection with access from the County Road.
3. Certain traffic control devices, such as traffic signals, construction signing, pavement markings installed by the permittee within the highway right of way with permission of the Ulster County Department of Public Works must be energized, operated and maintained by the permittee as specified by the Department.
4. Piped or channelized drainage shall not be permitted to flow onto a highway right of way unless specifically approved by the Department in an approved manner.
5. The permittee shall remove all excavated and surplus material to an area outside the highway right of way unless the permit provides for disposal at specific locations within the highway right of way.
6. A copy of the permit must be at the site at all times in order to verify permit issuance and must be provided to the County representative upon request. The authorized permit issued at the time of permit must be mounted on a tree or post where it may be seen plainly.
7. The permittee is responsible for the completion of all authorized work. If involved property is transferred before satisfactory completion of said work permit, a new permit must be issued and related securities must be deposited by the new permittee.
8. The permittee agrees to pay any cost for testing or inspection of the work authorized by the permit as required by the Commissioner of Public Works or his representative. Payment for such testing or inspections shall be made within thirty (30) days of billing.

9. The contractor will be responsible for the following:
 - a. Removal and replacement of all signs, guide rail, posts, postal delivery boxes, culvert pipes, headwalls, etc. If damaged, contractor shall supply and install new.
 - b. Replacement of all drainage swales with backfill material and final surface as directed by the Ulster County Department of Public Works.
 - c. Topsoil, seed and mulch all disturbed lawn areas.
 - d. Soil erosion control of all disturbed embankments.
 - e. All pavement damage must be cut and overcut for final surface restoration of 3 inches of asphalt binder and 2 inches of asphalt top course. Thicknesses as stated are compacted finish thickness. All existing pavement edges must have approved tack coat prior to new asphalt restoration.
 - f. No construction materials or equipment may be stored within the County Road right of way during non-working hours.
 - g. All traffic lanes must be back in service by 4:30 P.M. or as otherwise directed by the Ulster County Department of Public Works. Trenches may not be left open overnight. Normal working hours are from 7:00 A.M. to 3:30 P.M. The Ulster County Department of Public Works must approve any change to these hours in advance.
 - h. The job site must be swept daily using a mechanical sweeper. If the mechanical sweeper is not operational at the start of the day, the sweeper must be repaired during the day. If the sweeper is not available by the end of the day, a penalty will be imposed for non-performing equipment. If the sweeper is not repaired by the following day, the contractor will not be allowed to excavate.

10. With reference to a proposed Highway Work Permit application, the following will be required prior to the issuance of said Permit.
 - a. Furnish two certified checks payable to the Ulster County Commissioner of Finance one check as an Inspection/Application Fee in the amount (to be specified by the department), and a second check as a Performance Deposit in the amount (to be specified by the department).
 - b. Letter listing the following suppliers with proper certification are required:
 - Controlled Density backfill
 - NYSDOT subbase
 - NYSDOT asphalt
 - c. List of responsible people to contact in case of emergency during weekends and non-working hours.
 - d. Letter of request for steel plate use and steel plate certifications, if use is anticipated.
 - e. Provide three copies of a proposed work zone protection layout.
 - f. Copies of all delivery slips for materials listed above will be required for each day's delivery and placement.

SECTION III

DESIGN AND CONSTRUCTION STANDARDS

The design standards, which are herein presented, are based on the premise that the right of way users and abutting property owners can be mutually satisfied. Variations in site and conditions are accommodated in permissible ranges indicated.

A. ACCESSES, GENERAL

1. The access shall be located entirely within the permittee's property frontage to provide:
 - a. The most favorable sight distance, grade and alignment conditions for the motorist along the highway and proposed driveway without undue interference with the free and safe movement of through highway traffic.
 - b. Maximum safety and convenience for pedestrians, bicyclists and other users of the highway right of way.
2. In the interest of public safety and convenience, the Ulster County Department of Public Works will restrict the placement of a driveway to a particular location along the owner's frontage.
3. The grades of access drives shall be constructed to slope down and away from the highway pavement at a minimum negative 2 percent (-2%) grade from the edge of travel lane (white line) for 20 feet.
4. Where curb cuts are made for the construction of driveways, curb cut ends shall be tapered from full height to a 2-inch lip in a distance of approximately 2 feet.
5. Some of the drainage considerations that must be addressed in design and location of driveways are:
 - a. A driveway must be constructed so that it does not adversely affect the highway drainage or drainage of the adjacent property. The drainage and the stability of the highway sub-grade should not be impaired by driveway construction or roadside development. In no case shall the construction of a driveway cause water to flow across the highway pavement or to pond on the shoulder or in the ditch line.
 - b. Drainage collected by ditches, gutters or pipes on private property shall not be discharged into the highway drainage unless expressly approved by the Ulster County Department of Public Works. The permittee may be required to submit to the Department a drainage study justifying the drainage system proposed and the pipe size used.
 - c. Where the construction of a driveway necessitates crossing a highway ditch, a culvert pipe shall be installed in the ditch line or as shown on the approved designed plans by the permittee. The existing ditch line must be re-aligned to and from the proposed culvert and the ditch line cleaned and graded across the entire project frontage to

insure positive flow. Under no circumstances will the existing ditches or gutters be filled without adequate provisions for alternate drainage by the permittee.

- d. Culvert pipes shall be at a size adequate to carry the anticipated flow in the ditch as determined by the design professional and shall not be smaller than 15 inches diameter of the material as specified in other sections of these standards. The length of the culvert shall be no less than 20 feet and shall accommodate a stone side slope of one vertical to three horizontal. Flared End Sections and 6 feet of stone on either side shall be provided and constructed as approved by the Ulster County Department of Public Works.

All reinforced concrete culvert pipe, corrugated metal pipe and/or smooth interior high density polyethylene pipe (HDPE) shall conform to the requirements of the NYS Department of Transportation Standard Specifications, latest edition.

- e. Where no pipe is required, a swale shall be constructed across the driveway as shown on the approved plans and permit.
 - f. No existing drainage channel or ditch affecting a County Road shall be blocked or filled in and no changes shall be made to any existing stream, ditch, channel or drainage structure unless specifically noted on the approved plan and permit.
 - g. No change in the direction of runoff to or from the property shall be made unless specifically noted on the approved plans and permit.
6. All landscaping located within the line of sight from points of access and along the County Road shall be removed. The permittee is responsible for trimming vegetation outside the line of sight to maintain sight distances. No trees, bushes, fences, stonewalls or other landscaping walls, retaining walls, fences or other structures shall be placed within the highway right of way.
 7. All Off Street Parking spaces must be provided outside of the highway right of way line (not pavement line), unless approved by the Ulster County Department of Public Works.
 8. If two roads are available, entrance shall be from the least heavily traveled road or as determined by the Ulster County Department of Public Works.
 9. Guide Rail:
 - a. Show location of proposed Guide Rail and/or modifications to existing Guide Rail
 - b. Proposed Guide Rail and modifications to existing Guide Rail must be in conformance with the latest design specifications of the NYS Department of Transportation. Provide all necessary details on the plans.
 - c. All Guide Rail work shall be performed by an experienced, professional guide rail contractor. The contractor shall be subject to Ulster County approval.
 10. The County's standard note **"No site preparation or construction, including utility connections, shall commence until a valid Highway Work Permit has been secured from the Ulster County Department of Public Works under Section 136 of the Highway Law"** must be on all sheets of the project plan set.

B. RESIDENTIAL ACCESS

1. Unobstructed sight distance, in conformance with the latest AASHTO Standards, must be provided and maintained by the permittee in both directions of the highway from the point of access.
2. A minimum of 12” of compacted gravel subbase foundation shall be provided as/under access aprons from the edge of travel lane (white line) for 20 feet or to the right of way line, whichever is greater.
3. Only one access shall be permitted for each residential building lot, unless specifically authorized and approved by Ulster County Department of Public Works.

C. SITE PLAN/SUBDIVISION

1. The County’s standard note **“No site preparation or construction, including utility connections, shall commence until a valid Highway Work Permit has been secured from the Ulster County Department of Public Works under Section 136 of the Highway Law”** must be on all sheets of the project plan set.
2. The County Road number and the Road Name must be on all plan views and Site Location Map.
3. The plans must contain a north arrow and a drawing scale.
4. The following existing physical features within the County Road Right of Way must be provided on the plan.
 - a. Show and label white lines (edge of travel lanes), center yellow lines, traffic patterns (turning lanes and directional cross hatching) where applicable, and painted Stop Bars.
 - b. Shoulders – label material.
 - c. Guide Rail and Guide Posts – label type.
 - d. Utility poles, anchors, anchor poles and direction of wires. Indicate if poles have streetlights.
 - e. Underground utilities: manholes (identify type – sewer, electric, etc.) catch basins (identify if there are curb or ditch inlets), Electric, telephone and cable boxes and pull boxes, valves and regulator stations.
 - f. Drainage: Culverts along and crossing the County Road – label size, type and inverts, Headwalls, Flared End Sections and drainage ditches – indicate direction of flow.
 - g. All signage.
 - h. Driveways and roads on the opposite side of the County Road Right of Way.
 - i. Traffic lights (show locations of signal heads), strain poles, pull boxes, cabinets and loop detectors where applicable.
 - j. Trees, bushes, (label size and type if applicable), fences, stonewalls, retaining walls and any other landscape item.

- k. Topography within the County Road Right of Way – 2 foot contours showing both existing and proposed grades.
- l. Distances from all angle points and corners from the front property line to the center of existing pavement of the County Road.
- m. Provide Lot Nos. Tax Map number, boundary lines and names of adjacent property owners.

5. Proposed information:

- a. Profile: Residential driveways must be graded at a -2% grade from the edge of travel lane (white line) for 20 feet.
- b. Roads (public and private) and commercial driveways: Provide a -6% grade from the edge of travel lane for 6 feet (shoulder grade). From the end of the -6% grade use a -2% grade, the next interior proposed grade and use a vertical curve at a length to create a low point 25'± from the edge of travel lane.
- c. Cross Section: Residential driveways must be paved from the edge of travel lane for 20 feet with 12" of compacted NYSDOT Item 4 sub-base and 2" of Asphalt Top Course. Roads (public and private) and commercial driveways must be paved from the edge of travel lane for 50 feet with 12" of compacted NYSDOT Item 4 Sub-base, 3" of Asphalt Binder Course and 2" of Asphalt Top Course.
- d. Drainage:
 - Show location and provide details for all catch basins and drainage manholes – label inverts.
 - Show location of culverts – label diameter, length, inverts and type. Culverts must have Flared End Sections and 6 feet of Rip Rap.
 - Drainage Ditches: Existing drainage ditches along the County Road must be realigned to and from the proposed culverts. Existing ditches must be cleaned and graded across the entire project frontage to insure positive flow. Show location of drainage ditches and drainage flow from existing culverts along and crossing the County Road, through the proposed project if any.
- e. Guide Rail: Show location of proposed Guide Rail and/or modifications to existing Guide Rail. Proposed Guide Rail and modifications to existing Guide Rail must be designed in conformance with the latest specifications of the NYSDOT. Provide all necessary Details on plans.
- f. Signage: Show locations and provide details for all required signage in conformance with the National Manual of Uniform Traffic Control Devices for Streets and Highways, latest edition and the New York State Supplement, latest edition.
- g. Provide Roadway Striping location and details where applicable.
- h. Utilities:
 - Show location and provide Construction Details of all proposed underground and overhead utilities.
 - All underground utilities crossing a County Road must be bored unless authorized by the Ulster County Department of Public Works to be open cut.
 - All Underground utilities (except drainage) must be placed within Steel Sleeves if bored or within HDPE smooth bore pipe sleeves if installed by Open Cut. Provide Sleeve and Bulk Head Details.

- All Trenches within pavement areas must be backfilled with Controlled Density Backfill from the top of pipe cushion to the bottom of pavement compacted in 12” lifts.
 - All Trenches within 8 feet of pavement areas must be backfilled with N.Y.S. approved backfill (NYSDOT Item 4) from the top of pipe cushion to the top of trench in 12” lifts.
 - Show proposed Easements. Easements to be dedicated to the County of Ulster must be labeled on the plan as “Offered for Dedication to the County of Ulster”. The following note must be placed on the plan: “The Developer/Owner irrevocably offers to grant easements as shown on the Plat as Offered for Dedication to the County of Ulster.” Easements to be dedicated to others must be appropriately labeled.
 - Where traffic signal loop detectors are installed at UCDPW owned traffic signals, easements for the loops must be dedicated to the County of Ulster.
- j. All driveways must have a turn-around area to insure vehicles will not back out onto any County Road.
- k. Sidewalks and curbs: Prior to allowing sidewalks and curbs within any County Road right of way a Revocable License Agreement must be signed and executed by the municipality that the County Road is located in and the County of Ulster. The sidewalks and curbs are to be designed and built in conformance with the specifications of the municipality that they will be located in. Detectable Warning Devices must be installed as required by Federal Law and ADA accessibility guidelines.

6. Right of Way Monumentation: Where a parcel abutting the County highway is subdivided, the permittee shall be required to provide permanent monumentation of the highway boundary in a manner acceptable to the Commissioner of Public Works or his representative. Monuments shall be installed at all locations where existing or proposed property lines meet the highway boundary. Monumentation shall be installed by a professional land surveyor licensed to practice in New York State.
7. Sight Distance:
 - a. Show existing and proposed Sight Distances in both directions from each proposed driveway and road entrance. Proposed Sight Distances must be in conformance with AASHTO, latest edition for Stopping Sight Distances for vehicles traveling on the County Road and left and right Turning Sight Distances for vehicles exiting the proposed site.
 - b. Provide a Sight Distance profile for each direction, as required.
 - c. Provide Sight Distance Easements for the maintenance of Sight Distance as required.
8. Landscaping: No trees, bushes, fences, landscape walls, stone walls, pillars, retaining walls or any permanent structure will be allowed within the County Road Right of Way.
9. Soil Sedimentation Control:
 - a. Show location and provide Details for Soil Sedimentation Control Devices. Sedimentation Control must be provided for all existing and proposed culverts, ditches and drainage structures.
 - b. Show location and provide Details for a Stabilized Construction Entrance for all areas where construction equipment will enter the proposed site from a County Road.

D. NEW STREETS AND COMMERCIAL ACCESS

1. Access serving a single commercial or industrial establishment shall be accepted by the Ulster County Department of Public Works with consideration to the traffic conditions that prevail. The access point may be limited in number and location due to sight distances and traffic constraints.
2. The intersection angle of new streets or access drives centerline shall be as close to 90° as possible to the edge of travel lane (white line).
3. Sight distances must be in conformance with AASHTO, latest edition.
4. Whenever deemed necessary by the Ulster County Department of Public Works, channelization shall be provided between the highway and the adjoining facility.
 - a. The element of channelization island area nearest to the highway shall be located either at the ditch line, curb line or outer edge of pavement of uncurbed highways. The island area shall extend at least to the right of way line. The length of island area at the shoulder edge will be determined by the angle of the access and the width of

the right of way. Concrete curbing, posts, guide rail or other suitable channelization material, shall delineate all island areas within the right of way. Loose stone gravel surfacing shall be considered unsuitable for this purpose.

- b. The length, width and shape of the corner island areas will vary for different locations. The angle of intersections, angle of accesses, and width of right of way on both approaches, channelization, radii and other conditions will influence the location of accesses at intersections. The angle of an approach in relation to the highway intersection shall be such that an exiting vehicle may merge in the lane of traffic moving in the desired direction before crossing the intersection and that a vehicle entering the facility from the intersection may do so in an orderly and safe manner with a minimum of interference to through traffic.
- c. In order to maintain visibility at new street intersections, public or private, the Ulster County Department of Public Works may require the deeding of sight distance easements to the appropriate municipal authority.
- d. Commercial and industrial installations will be allowed no more than two accesses unless otherwise approved by the Ulster County Department of Public Works.
- e. In cases where commercial or industrial installations or subdivisions can be expected to generate a significant volume of traffic, the Ulster County Department of Public Works may require a traffic study to determine the possible necessity for entrance/deceleration lanes, traffic control devices or other means of reducing conflict with traffic on the County Road system.
- f. Subdivision plans shall be designed to reduce to a minimum the number of street connections and driveways to the County Road corridor.
- g. All projects requiring Municipal Planning Board approval must be submitted to the Ulster County Department of Public Works by the Municipal Planning Board in conformance with the provisions of Section 239-f of the General Municipal Law.

E. UTILITIES AND OTHER IMPROVEMENTS

The following conditions and standards apply to work authorized within a County Road right of way for electrical, telephone, fiber optic facilities, water mains, gas mains, sewer lines, storm sewers and other improvements.

1. All work locations and work areas must be shown on plans prepared in conformance with the above Standards and shall be approved by the Ulster County Department of Public Works prior to the issuing of a Highway Work Permit.
2. Encountered underground and overhead facilities shall not be disturbed in any manner without notification to and with proper authority of the owner.
3. All pipes or mains crossing a County Road must be placed within Steel Sleeves driven or bored beneath the roadway without disturbance to the pavement or its foundation, unless otherwise approved by the Ulster County Department of Public Works. The point of driving or boring shall not be less than six feet from the edge of pavement and shall be protected by vertical sheeting extending 36 inches above road shoulder elevation. After backfilling,

sheeting shall be cut at ground level or as directed by the Ulster County Department of Public Works.

4. If field conditions preclude the boring or driving of crossover pipes, the Ulster County Department of Public Works shall be consulted to determine the manner of placing the pipes by open cut. Crossover pipes installed by open cut must also be placed within HDPE smooth bore pipe Sleeves so that repairs or replacements may be made in the future without further disturbance of the County Road pavement.
 - a. On pavements and paved driveways where cutting is permitted, temporary repairs with hot asphalt or cold patch or other acceptable types of bituminous patching must be placed as soon as backfilling and compaction is completed and shall be maintained even with the surface of the adjacent pavement until such time as the restoration of the pavement surface. This method must be previously approved by the Ulster County Department of Public Works and will be only used for emergency service repairs where severe weather conditions do not permit more acceptable methods.
 - b. Where road pavements are cut, the trench shall be backfilled with Controlled Density Backfill (K-Crete), or approved equal, compacted in 12 inch lifts, or as directed by the Ulster County Department of Public Works.
 - c. Whenever the edge of the trench excavation is within 8 feet or less of the edge of road pavement or paved gutter, backfill consisting of N.Y.S.D.O.T. backfill (Item 4) approved by the Ulster County Department of Public Works shall be placed in 12 inch lifts. Each lift shall be thoroughly compacted by mechanical means (i.e. pad type vibratory compactor or drum roller). Compaction and material testing of backfill may be ordered by the Ulster County Department of Public Works depending on the complexity, depth and/or length of the excavation.
 - d. All trench areas greater than 8 feet distance from the pavement edge may be backfilled with select fill material from the trench excavation with all large stones to be removed and compacted in 12 inch lifts. Backfill in trenches beyond pavement and shoulder areas but within the County Road right of way must be maintained level with the surrounding surface at all times.
 - e. The contractor shall be responsible for shoring any trench or excavation that is greater than 5 feet deep or which, in the opinion of the Ulster County Department of Public Works inspector in the field poses a danger to the contractor's personnel on the job. The contractor has the option of using a prefabricated shoring system, installing a timber-constructed system approved by OSHA or other means designed by a New York State Licensed Engineer. No other shoring system will be approved for use.
 - f. Steel plates are **not** permitted to be used overnight on County Roadways. Steel plates may be used as a temporary measure during working hours to facilitate traffic flow through work areas and across excavated trenches. The use of steel plates must be approved in advance by the Ulster County Department of Public Works. If used, steel plates must be HS-20 load rated. Certification of load rating must be provided to the UCDPW before plates are used.
5. Pavement replacement shall be as specified by the Ulster County Department of Public Works in accordance with the following requirements.

- a. When required, a temporary pavement patch shall be placed consisting of asphalt concrete of a minimum of 5 inches in depth. It shall be maintained flush with the existing pavement until permanent restoration of pavement is made.
 - b. After the completion of backfill of an open trench, a pavement patch shall be placed in the following manner. The damaged pavement shall be overcut by 2 feet minimum beyond both edges of trench walls or to the extreme limit of pavement damage. The pavement shall be replaced with a minimum compacted depth of 3 inches of asphalt Binder Course and a wearing surface of asphalt top course placed and rolled by means of a ten-ton steel roller to a minimum depth of 2 inches, meeting the grade of the old pavement. A bituminous sealer shall be placed at joints of the old and new pavement. Pavement material shall conform to applicable NYSDOT Specifications.
 - c. Paved shoulders that are damaged in the course of work shall be restored as specified by the Ulster County Department of Public Works and shall be equal to or better than the type and material damaged.
 - d. Manhole frames and covers shall be of an approved type and set in a workmanlike manner flush with the surface of the highway pavement.
6. Traffic shall be maintained and protected in the following manner and in conformance with National "Manual of Uniform Traffic Control Devices for Streets of Highways" latest edition and the New York State supplement latest edition and revisions. A plan for the maintenance and protection of traffic through any proposed work zone along a County Road must be included as part of the design plans.
- a. Generally, work zones within the County Road Right Of Way require the following warning signs for each approach at minimum: Road Work 1500 Feet, Road Work 1000 Feet, Road Work 500 Feet. In addition to these signs, supplemental warning signs such as "Shoulder Work", "One Lane Road Ahead", and "Lane Narrows", shall be used as required or ordered by the Ulster County Department of Public Works.
 - b. If in the judgment of the Ulster County Department of Public Works, flag persons are necessary, they shall be employed by the permittee and be on duty at all times during the progress of the work. Appropriate warning signs for flaggers shall be used.
 - c. No construction equipment or material shall be left on the shoulder or pavement after working hours, nor shall any equipment or material be placed in any manner or location that will obstruct highway traffic signs or railroad warning signs.
 - d. Soft shoulder signs of adequate size, not less than 36 inches by 36 inches, shall be erected and maintained on all trenches within the shoulder area until backfill has thoroughly settled. These signs shall be located as specified in the Codes, Rules and Regulations of the State of New York or as ordered by the Engineer.
 - e. During winter conditions, the traveled way shall be maintained free of obstructions, which would interfere with snow removal and ice control.
 - f. The permittee shall keep the travel lane free of debris or any material related to the authorized work. Spillage of any material from any vehicle of the permittee's hauling operations along or across any public traveled way shall be removed immediately from such traveled way both within and outside of the work limits, and the traveled way shall be kept free of such spillage by the permittee.

- g. All entrances onto a County Road shall have a Stabilized Construction Entrance in conformance with the Details provided elsewhere in these Policy & Standards, placed prior to the start of any construction and shall be maintained by the permittee until placement of final pavement.
- 7. If it is determined by the Ulster County Department of Public Works that due to construction activities, numerous cuts, gouges, scars, settlement or patches have occurred, the permittee will be obligated to top the County Road the full width of the road and length of the project with a 2 inch asphalt top course.
- 8. Any structure, pipe, guide rail and appurtenances, sign delineators, or underground facilities which have been broken, damaged, or excavated, or which have settled due to excavation or causes thereof, will be replaced or repaired to the satisfaction of the Ulster County Department of Public Works.
- 9. If necessity arises in the future, because of the work on the County Road, to make repairs pertaining to this permit, said work shall be done at the expense of the permittee/applicant.
- 10. Overhead utility installations shall conform to the following standards.
 - a. All utility poles shall be set outside the ditch lines and at a minimum of 10 feet from the road pavement edge, unless otherwise approved by the Ulster County Department of Public Works, and so that there is no interference to the proper drainage of the highway.
 - b. There shall be no obstruction to private driveways, connection highways or roads, paths and sidewalks.
 - c. When improvements to the County Road necessitate the relocation and/or replacement of poles, cables or conduit, said work shall be done at the expense of the permittee.
 - d. Where poles are proposed to be set behind guiderails, poles must be placed beyond the deflection distance of the guiderail for a "Standard Impact". A Standard Impact is produced when a 2000P (Pickup truck, 2000 kg) test vehicle traveling at 60 MPH impacts the barrier at a 25 degree angle. In cases where poles cannot be placed beyond the deflection distance of the existing guide rail, the rail shall be improved or replaced to reduce the rail deflection distance.

SECTION IV

DEFINITIONS

Residential Access: A driveway servicing four or fewer homes or an apartment building for four or fewer dwelling units.

Commercial Access: A driveway servicing a commercial establishment, industry, governmental or educational institution, private utility, hospital, church, apartment building or other comparable traffic generator.

Utility Work: Installation, modification or repair of power lines, energy distribution systems, communication systems, water mains, sanitary sewer and storm drainage systems.

Sight Distance: The distance from where an object remains visible to an observer; further defined for specific application as follows:

- A. **Stop Line Sight Distance:** Travel distance for which a vehicle approaching on a highway would be continuously visible to a driver waiting to enter from an intersecting road or driveway.
- B. **Stopping Sight Distance:** Distance of continuous line of sight from a vehicle traveling on a highway to a vehicle waiting to enter from an intersecting road or driveway.
- C. **Turning Sight Distance:** Distance of continuous line of sight from a vehicle making a left or right turn onto a highway and an oncoming vehicle.

Sight Distances shall be measured in conformance with AASHTO, latest edition.

All grading and clearing required on the approved plans for establishment of the proposed sight distances must be done immediately upon issuance of the work permit and prior to beginning construction activities.

SECTION V

SPECIAL CONDITIONS

In addition to the aforementioned conditions if it is found necessary by the Ulster County Department of Public Works to add or otherwise modify the same, it is to be understood such changes shall form a part of the permit and be complied with immediately upon notice.

It would be impossible to set down requirements for every condition. Therefore, the Ulster County Department of Public Works reserves the right to inspect all materials and methods of construction within the County Road right of way.

Any variance to the aforementioned requirements shall be submitted to the Ulster County Department of Public Works in a written request for approval.

The Ulster County Department of Public Works reserves the right to change any of the requirements and an addendum of such change will be forwarded to the Municipalities.

SECTION VI

SOIL EROSION & SEDIMENT CONTROL:

All soil erosion & sediment control must be detailed on plans and shall conform to the New York State Department of Environmental Conservation Design Manual as applicable.

All soil erosion & sediment control measures must be in place after permit issuance and prior to construction start or as directed by the Ulster County Department of Public Works and shall be inspected and maintained by the permittee throughout the project.

SECTION VII

FORMS & SKETCHES

The following samples and detail sheets, forms and sketches are presented to illustrate the requirements outlined in the preceding paragraphs. It is not feasible to develop a detailed layout sketch for all likely combinations of major factors in the performance of all types of work. Instead, these general requirements and standards are presented for the controls, more or less common to all work. **With these as a guide, the design professional can work out desirable plans for most conditions. The details presented on plans for review and approval must show actual project conditions, grades and proposed dimensions.**

Where the words “Approved”, “Or Equal”, “As Directed” and similar expressions occur in the “Policy & Standards” they refer to the specific approval or as directed by the Ulster County Department of Public Works.

The various materials mentioned in these “Policy & Standards” including those where proprietary names are used, whether or not followed by the words “or as approved equal” are given the establish a standard of quality of construction and it is not the intent to limit the materials, but rather to set up the standard desired or acceptable, and to establish a basis of equality, and they shall be subject to the equals as approved by the Ulster County Department of Public Works.

ULSTER COUNTY DEPARTMENT OF PUBLIC WORKS

To: Commissioner of Public Works

Tel: 845-340-3100

Fax: 845-340-3113

APPLICATION FOR A COUNTY ROAD PERMIT

Department of Public Works

317 Shamrock Lane

Kingston, NY 12401

Application is hereby made for permission under Section 136 of the Highway Law, to enter upon and construct the following facilities on the following named Ulster County Road:

Permit # _____ **Permit Type** _____

(Subdivision Road, Major Driveway Access, Utility, etc.)

Owner / Applicant Information

Name _____
Contact _____
Address _____
City _____
State, Zip _____
Phone _____
Fax _____
Cell phone _____
Email _____

Contractor Information

Name _____
Contact _____
Address _____
City _____
State, Zip _____
Phone _____
Fax _____
Cell phone _____
Email _____

Location

Street (County Road #) _____ **Segment(Official use only)** _____

Address _____

Location _____

Purpose _____

Special Conditions _____

Town, Section-Block-Lot # _____, _____ - _____ - _____

In County Pavement Yes No **Size** _____ **Depth** _____

If permit is granted, I hereby agree to all the conditions and restrictions forming a part of this permit and to restore to its original condition, any portion of the road, shoulders or drainage that may be disturbed.

IF, AFTER SUFFICIENT TIME AS DETERMINED BY THE COMMISSIONER OF PUBLIC WORKS, OR THEIR REPRESENTATIVE, THE WORK TO BE PERFORMED UNDER THIS PERMIT IS NOT COMPLETED, SAID PERMIT SHALL BE CANCELLED AND THE DEPOSIT WILL BE FORFEITED.

(Owner / Applicant Signature) **(Title)** **(Date)**

Permission is hereby granted to perform work enumerated above, subject to attached conditions and restriction. A Certified Check made payable to the ULSTER COUNTY COMMISSIONER OF FINANCE, is to be deposited as a guarantee that the work shall be completed in compliance with this permit and that the road will be restored to its original condition at the expense of the owner/applicant.



Signature: _____ Date: _____
 For: COMMISSIONER OF PUBLIC WORKS

Signature: _____ Date: _____
 UCDPW REVIEWER

OFFICIAL USE ONLY

Date Submitted _____ **Temp. Patch Date** _____ **App. Ck.#** _____

Date Issued _____ **Temp. Patch Contractor** _____ **Insp. Ck.#** _____

Start Date _____ **Perm. Patch Date** _____ **Bond \$** _____

Expiration _____ **Perm. Patch Contractor** _____

Reviewers Initial _____ **Review Status:** **Closed** **Pending** **Public** **Received** **Technical**
 _____ (circle one) **Decision** **Hearing** **Review**

Decision Date _____ **Decision:** **Approved** **Conditional** **Denied** **Withdrawal**
 _____ (circle one) **Approval**

OWNER / APPLICANT SHALL FURNISH FULL INFORMATION AS TO THE NATURE OF THE WORK TO BE UNDERTAKEN, LOCATION, DETAILS OF STRUCTURE(S) INVOLVED, ETC., AND SHALL ATTACH A SKETCH SHOWING LOCATION AND AREA AFFECTED.

Two (2) original copies of this application are to be executed by Owner / Applicant with approving signatures. When approved by County Commissioner, one copy will be returned to Owner / Applicant.

A PROPERLY EXECUTED COPY OF THIS PERMIT MUST ALWAYS BE AVAILABLE ON THE WORK UNDERTAKEN, TO BE SUBMITTED TO THE ENGINEER AT HIS REQUEST.

Conditions and Restrictions

THE FORGOING PERMIT IS GRANTED SUBJECT TO THE FOLLOWING GENERAL CONDITIONS, AND SUBJECT TO THE "SPECIFICATIONS AND RESTRICTIONS GOVERNING WORK DONE UNDER PERMITS".

1. This permit shall not be assigned or transferred except with the written consent of the County Commissioner.
2. The work authorized by this permit shall be done to the complete satisfaction of the County Commissioner or his representative. In replacement of pavements, the Standard County Specifications therefore shall be followed.
3. Notice shall be given by said Application to the County Commissioner at least 48 hours in advance of the date when the work is to begin.
4. The Owner / Applicant hereby agrees to indemnify and save harmless the County from all suits, actions of damages of every kind whatsoever which may arise from or on account of the work to be done under this permit. General Liability Insurance for the protection of the Owner / Applicant and the County will be maintained in such an amount and in such company and in such case as the County Commissioner may require.
5. The Owner / Applicant agrees, in consideration of this permit, that any present or future injury to or disturbance of the road, its pavement, shoulders, its slopes or gutters, caused by the work proposed under this permit, shall be repaired by the Owner / Applicant at his/her own expense and to the complete satisfaction of the County Commissioner.
6. The County Commissioner reserves the right to revoke or cancel this permit at any time should the Owner / Applicant fail to comply with the terms and conditions herein prescribed.
7. Owner / Applicant's approved copy of this permit shall be in possession of the parties actually doing the work. It must be furnished on demand, to the County Commissioner or his representative.
8. The Owner/Applicant is responsible to attain any additional required permits/permissions including, but not limited to, applicable Federal, State and Local permissions.
9. Traffic shall be maintained on this section of the road by the Owner / Applicant during the life of this permit in accordance with the National Manual of Uniform Traffic Control Devices, latest Edition.
10. The Owner / Applicant hereby certifies that he has secured compensation for the benefit of, and will keep insured during the performance of the above described work, such employees as are required to be insured by the provisions of Chapter 41 of the Laws of 1914 and Acts amendatory thereof, known as the Workmen's Compensation Law.
11. If necessity arises in future, because of this work on the highway, to make repairs pertaining to this permit, said work shall be done at the expense of the Owner / Applicant.
12. The County shall not be held responsible for any damage/injury due to poor sight distances that may exist.

Refer to Schedule A for Special Conditions if Box is Checked.

I HEREWITH AGREE TO THE ABOVE "CONDITIONS AND RESTRICTIONS"

DATE

(OWNER / APPLICANT)

Notification Procedure
Prior to Starting Work

Notice shall be given by said Owner / Applicant to the County D.P.W. Permit Office at least 48 hours in advance of the date when work is to begin.

Failure to comply with the notification procedure outlined above may result in revocation of your permit and forfeiture of all fees.

County Permit Office:
(845) 340-3119

Permit No.: _____

I herewith agree to the above conditions.

Date

Owner / Applicant (please print)

Owner / Applicant Signature

FOR DEPOSITING PURPOSES PLEASE INDICATE BY CIRCLING BELOW WHO THE MONEY IS

TO BE DEPOSITED UNDER:

APPLICANT / OWNER (OR) CONTRACTOR

Be advised that the name and address on the Performance Deposit is required to match the name and address on the application

Ulster County DPW Schedule of Fees for Permits - Work within County R.O.W.			
	Application Fee	Inspection Fee	Performance Deposit
Renewal After One Year	\$25.00	Original Inspection Fee	
Logging, or Other Temporary Entrances	\$25.00	\$100.00	\$2,000.00
Minor Driveway Access (residential, farm, etc)	\$25.00	\$75.00	not applicable
All Private Utility (Gas, Water, Sanitary, Storm Sewer, etc.) Crossings - Controlled Density Backfill Open Cut and/or Boring Perpendicular & Longitudinal to (across & along) Road, including restoration.	\$25.00	\$200.00 minimum and \$100.00 per day each day after 2 days.	\$2,500.00 minimum and up (based on estimated construction cost within R.O.W.)
Major Driveway Access (commercial, curbs, drainage structures, etc)	\$25.00	\$300.00 minimum or 4% of construction cost, whichever is greater.	\$3,000.00 minimum and up (based on estimated construction cost within R.O.W.)
Subdivision Entrance with Appurtenances	\$25.00	\$250.00 minimum or 4% of construction cost, whichever is greater.	\$2,500.00 minimum and up (based on estimated construction cost within R.O.W.)
<p><u>ALL</u> fees shall be paid separately - payable to the <u>"Ulster County Commissioner of Finance"</u>. <u>Performance Deposits and Inspection Fees are required to be a Bank Check, Certified Check or Money Order.</u></p>			



Location Request - Information Sheet

Filling out this form does not constitute as a valid location request. This form is simply a reference and guide to what information will be asked of you when placing a location request.

Company ID# _____ Today's Date _____

Company Name _____

Company Mailing Address _____

City _____ State _____ Zip _____

Phone _____ Fax _____

Email _____

Field Contact Name _____ Phone _____

Name or company for whom you are doing the work?

NYS Law requires at least 2 full working days advance notice, not including the day you call.

Start Date _____ Start Time _____

Duration of job _____

Days Hours Months Weeks Years Unknown (check one)

Excavation site state New York County _____

City Town Village (check one) _____

Street Address _____

The TWO nearest cross streets the address is located between

Near Street 1 _____

Near Street 2 _____

Where on the property are you excavating? _____

Depth of excavation _____ Inches Feet (check one)

Length of excavation _____ Feet Miles Meters (check one)

Width of excavation _____ Inches Feet (check one)

Type of work _____

Means of excavation _____

Will there be blasting? Yes No

Will there be boring or directional drilling? Yes No

Is the dig site within 25ft from the edge of the road or in the road? Yes No

Are you digging on both sides of the road? Yes No

Is the excavation marked in WHITE? Yes No

Notes

To view a list of members that were notified, visit your



To find this, visit www.digsafelynewyork.com and click the APR logo on the home page

Location requests can be placed 24 hours a day 7 days a week online using i-notice or by calling 811

For a digital copy: www.digsafelynewyork.com/resources



SUBMIT TICKETS ONLINE 24 HOURS A DAY

Contact our I-Notice Customer Service Representative today to get started!

1.800.309.8289

Dig Safely New York, Inc. 5063 Brittonfield Parkway • East Syracuse, NY 13057

www.DigSafelyNewYork.com

Summary of Ulster County Insurance Requirements:

Item Numbers 1-3: See the attached Sample Certificate of Insurance (Accord Form) for the required minimum limits and the language required for the Additional Insured and Certificate Holder Notes.

Item No. 4: See the following Part 1 and Part 2 lists of the appropriate acceptable forms for Worker's Compensation and Disability Benefits. *Please note that the Accord Form is no longer acceptable proof of NYS Workers' Compensation and Disability Benefits Insurance Coverage*

Part 1: Acceptable forms for Workers' Compensation: Provide one of the following.

C-105.2 or U-26.3 or GSI 105.2

Part 2: Acceptable forms for Disability Benefits: Provide one of the following.

DB 120.1 or DB-155

OR

Starting December 1, 2008, ONLY applicants eligible for **exemptions** must file a **new CE-200** for **each** and **every** new or renewed permit, license or contract issued by a government agency. Each CE-200 will specifically list the issuing government agency and the specific type of permit, license or contract requested by the applicant. Applicants for building permits will also need to supply additional information including identifying the specific job location and the estimated cost of the project.

Please ensure that the legal entity name on Form CE-200 exactly matches the legal entity name that is applying for the permit, license or contract. Please also ensure that the applicant signs and dates Form CE-200.

Each CE-200 will have a certificate number printed on it. Form CE-200s may be verified on the Board's web site at www.wcb.state.ny.us.

The applicant attests under penalty of perjury that the information contained in the CE-200 is accurate – the Board does not initially verify this information. However, Board staff may investigate applicants filing Form CE-200.

**** Be sure to forward the following pages to your insurance company to ensure the proper insurance coverage to is submitted Ulster County.**

ACORD CERTIFICATE OF LIABILITY INSURANCE

DATE MM/DD/YY

PRODUCER	THIS CERTIFICATE IS ISSUED AS A MATTER OF INFORMATION ONLY AND CONFERS NO RIGHTS UPON THE CERTIFICATE HOLDER. THIS CERTIFICATE DOES NOT AMEND, EXTEND OR ALTER THE COVERAGE AFFORDED BY THE POLICIES BELOW.
	COMPANIES AFFORDING COVERAGE
INSURED	COMPANY A
	COMPANY B
	COMPANY C
	COMPANY D

COVERAGES
 THIS IS TO CERTIFY THAT THE POLICIES OF INSURANCE LISTED BELOW HAVE BEEN ISSUED TO THE INSURED NAME ABOVE FOR THE POLICY PERIOD INDICATED, NOTWITHSTANDING ANY REQUIREMENT, TERM OR CONDITION OF ANY CONTRACT OR OTHER DOCUMENT WITH RESPECT TO WHICH THIS CERTIFICATE MAY BE ISSUED OR MAY PERTAIN, THE INSURANCE AFFORDED BY THE POLICIES DESCRIBED HERIN IS SUBJECT TO ALL THE TERMS, EXCLUSIONS AND CONDITIONS OF SUCH POLICIES, LIMITS SHOWN MAY HAVE BEEN REDUCED BY PAID CLAIMS.

ITEM 1

CO LTR	TYPE OF INSURANCE	POLICY NUMBER	POLICY EFFECTIVE DATE (MM/DD/YY)	POLICY EXPIRATION DATE (MM/DD/YY)	LIMITS
	GENERAL LIABILITY <input checked="" type="checkbox"/> COMMERCIAL GENERAL LIABILITY <input type="checkbox"/> CLAIMS MADE <input checked="" type="checkbox"/> OCCUR <input checked="" type="checkbox"/> OWNER & CONTRACTOR'S PROT <input type="checkbox"/> _____				GENERAL AGGREGATE \$ 1,000,000.00 PRODUCTS-COMP/OP AGG \$ 1,000,000.00 PERSONAL & ADV INJURY \$ 1,000,000.00 EACH OCCURRENCE \$ 1,000,000.00 FIRE DAMAGE Any one fire \$ 50,000.00 MED EXP Any one person \$ 5,000.00
	AUTOMOBILE LIABILITY <input type="checkbox"/> ANY AUTO <input type="checkbox"/> ALL OWNED AUTOS <input type="checkbox"/> SCHEDULED AUTOS <input type="checkbox"/> HIRED AUTOS <input type="checkbox"/> NON-OWNED AUTOS <input type="checkbox"/> _____				COMBINED SINGLE LIMIT \$ - BODILY INJURY Per person: \$ - BODILY INJURY Per accident: \$ - PROPERTY DAMAGE \$ -
	GARAGE LIABILITY <input type="checkbox"/> ANY AUTO <input type="checkbox"/> _____				AUTO ONLY-EACH ACCIDENT \$ - OTHER THAN AUTO ONLY \$ - EACH ACCIDENT \$ - AGGREGATE \$ -
	EXCESS LIABILITY <input type="checkbox"/> UMBRELLA FORM <input type="checkbox"/> OTHER THAN UMBRELLA FORM				EACH OCCURRENCE \$ - AGGREGATE \$ - \$ -
	WORKERS COMPENSATION AND EMPLOYERS' LIABILITY THE PROPRIETOR PARTNERS/ EXECUTIVE OFFICERS ARE: <input type="checkbox"/> INCL <input type="checkbox"/> EXCL				EL EACH ACCIDENT \$ - EL DISEASE-POLICY LIMIT \$ - EL DISEASE-EA EMPLOYEE \$ -
	OTHER				

ITEM 2

DESCRIPTION OF OPERATIONS; LOCATIONS; VEHICLES; SPECIAL ITEMS
Ulster County, PO Box 1800, 244 Fair Street, Kingston, NY 12402 is named as an additional insured with respect to work performed by the insured.

ITEM 3

CERTIFICATE HOLDER County of Ulster PO Box 1800 244 Fair Street Kingston, NY 12402	CANCELLATION SHOULD ANY OF THE ABOVE DESCRIBED POLICIES BE CANCELLED BEFORE THE EXPIRATION DATE THEREOF, THE ISSUING COMPANY WILL ENDEAVOR TO MAIL 10 DAYS WRITTEN NOTICE TO THE CERTIFICATE HOLDER NAMED TO THE LEFT, BUT FAILURE TO MAIL SUCH NOTICE SHALL IMPOSE NO OBLIGATION OR LIABILITY OF ANY KIND UPON THE COMPANY ITS AGENTS OR REPRESENTATIVES
---	--

Item No. 4: Workers Compensation and Disability Benefits

PART 1:

WORKERS' COMPENSATION REQUIREMENTS UNDER WORKERS' COMPENSATION LAW §57

To comply with coverage provisions of the Workers' Compensation Law ("WCL"), businesses must:

- A) be legally exempt from obtaining workers' compensation insurance coverage; or
- B) obtain such coverage from insurance carriers; or
- C) be a Board-approved self-insured employer or participate in an authorized group self-insurance plan.

To assist State and municipal entities in enforcing WCL Section 57, businesses requesting permits or seeking to enter into contracts **MUST provide ONE** of the following forms to the government entity issuing the permit or entering into a contract:

- A) **C-105.2** -- Certificate of Workers' Compensation Insurance (the business's insurance carrier will send this form to the government entity upon request) **PLEASE NOTE:** The State Insurance Fund provides its own version of this form, the **U-26.3**; **OR**
- B) **GSI-105.2** -- Certificate of Participation in Worker's Compensation Group Self-Insurance (the business's Group Self-Insurance Administrator will send this form to the government entity upon request), **OR** Certificate of Workers' Compensation Self-Insurance (the business calls the Board's Self-Insurance Office at 518-402-0247).

PART 2:

DISABILITY BENEFITS REQUIREMENTS UNDER WORKERS' COMPENSATION LAW §220(8)

To comply with coverage provisions of the WCL regarding disability benefits, businesses may:

- A) be legally exempt from obtaining disability benefits insurance coverage; or
- B) obtain such coverage from insurance carriers; or
- C) be a Board-approved self-insured employer.

Accordingly, to assist State and municipal entities in enforcing WCL Section 220(8), businesses requesting permits or seeking to enter into contracts **MUST provide ONE** of the following forms to the entity issuing the permit or entering into a contract:

- A) **DB-120.1** -- Certificate of Disability Benefits Insurance (the business's insurance carrier will send this form to the government entity upon request); **OR**
- B) **DB-155** -- Certificate of Disability Benefits Self-Insurance (the business calls the Board's Self-Insurance Office at 518-402-0247).

INSTRUCTIONS FOR OBTAINING FORM CE-200

The CE-200 is now an on-line application. Please remember that applicants are submitting the CE-200 under penalty of perjury, a felony carrying a penalty of four years jail time. Accordingly, all statements on the CE-200 must be true.

Applicants may access the CE-200 application on the Board's Website: www.wcb.ny.gov

1. Click on the button entitled "WC/WB Exemption Forms CE-200" (In bright yellow letters).
2. Click on the Request for WC/WB Exemption (Form CE-200).
3. Click the gray button on the bottom (Select to access web –based Application).
4. Applicants should create their own PIN number.
5. Follow the rest of the prompts.

It should take about 5 minutes to fill out the first time. **Applicants are required to print, sign and date Form CE-200 and send it to the Government Agency issuing their permit, license, or contract from.**

If the applicant is having difficulty in printing the CE-200, please call the Board's CE-200 Hotline at 866-546-9322, then press 1, and then press 3 and leave a voice message with the certificate number, the name of the business and a contact number. The CE-200 will be sent to the business address on the CE-200 within one business day.



**Certificate of Attestation of Exemption
From New York State Workers' Compensation
and/or Disability Benefits Insurance Coverage**

This form cannot be used to waive the workers' compensation rights or obligations of any party.

The applicant may use this Certificate of Attestation of Exemption ONLY to show a government entity that New York State specific workers' compensation and/or disability benefits insurance is not required. The applicant may NOT use this form to show another business or that business's insurance carrier that such insurance is not required.

Please provide this form to the government entity from which you are requesting a permit, license or contract. This Certificate will not be accepted by government officials one year after the date printed on the form.

<p align="center">In the Application of (Legal Entity Name and Address):</p> <p>JOHN SMITH 123 MAIN STREET ALBANY, NY 12207 111-111-1111 Federal ID Number: XXXXX6789</p>	<p align="center">Business Applying For: BUILDING PERMIT</p> <p align="center">From: CITY OF ALBANY, DEPT OF BUILDING AND CODES</p> <p>The location of where work will be performed is 123 ACME AVENUE, ALBANY, NY 12203. Estimated dates necessary to complete work associated with the building permit are from October 14, 2008 to March 31, 2009. The estimated dollar amount of project is \$25,001 - \$50,000</p>
---	---

Workers' Compensation Exemption Statement:

The above named business is certifying that it is **NOT REQUIRED TO OBTAIN NEW YORK STATE SPECIFIC WORKERS' COMPENSATION INSURANCE COVERAGE** for the following reason:

The business is owned by one individual and is not a corporation. Other than the owner, there are no employees, day labor, leased employees, borrowed employees, part-time employees, unpaid volunteers (including family members) or subcontractors.

Disability Benefits Exemption Statement:

The above named business is certifying that it is **NOT REQUIRED TO OBTAIN NEW YORK STATE STATUTORY DISABILITY BENEFITS INSURANCE COVERAGE** for the following reason:

The business is owned by one individual or is a partnership (LLC, LLP, PLLP or a RLLP) under the laws of New York State and is not a corporation; or is a one or two person owned corporation, with those individuals owning all of the stock and holding all offices of the corporation (in a two person owned corporation, each individual must be an officer and own at least one share of stock) or is a business with no NYS location. In addition, the business does not require disability benefits coverage at this time since it has not employed one or more individuals on at least 30 days in any calendar year in New York State. (Independent contractors are not considered to be employees under the Disability Benefits Law.)

I, JOHN SMITH, am the Sole Proprietor with the above-named legal entity. I affirm that due to my position with the above-named business I have the knowledge, information and authority to make this Certificate of Attestation of Exemption. I hereby affirm that the statements made herein are true, that I have not made any materially false statements and I make this Certificate of Attestation of Exemption under the penalties of perjury. I further affirm that I understand that any false statement, representation or concealment will subject me to felony criminal prosecution, including jail and civil liability in accordance with the Workers' Compensation Law and all other New York State laws. By submitting this Certificate of Attestation of Exemption to the government entity listed above I also hereby affirm that if circumstances change so that workers' compensation insurance and/or disability benefits coverage is required, the above-named legal entity will immediately acquire appropriate New York State specific workers' compensation insurance and/or disability benefits coverage and also immediately furnish proof of that coverage on forms approved by the Chair of the Workers' Compensation Board to the government entity listed above.

SIGN HERE	Signature:	Date:
<p>Exemption Certificate Number 2008-00197</p> 		<p>Received October 2, 2008 NYS Workers' Compensation Board</p> 

S-B-L

S-B-L

S-B-L

S-B-L

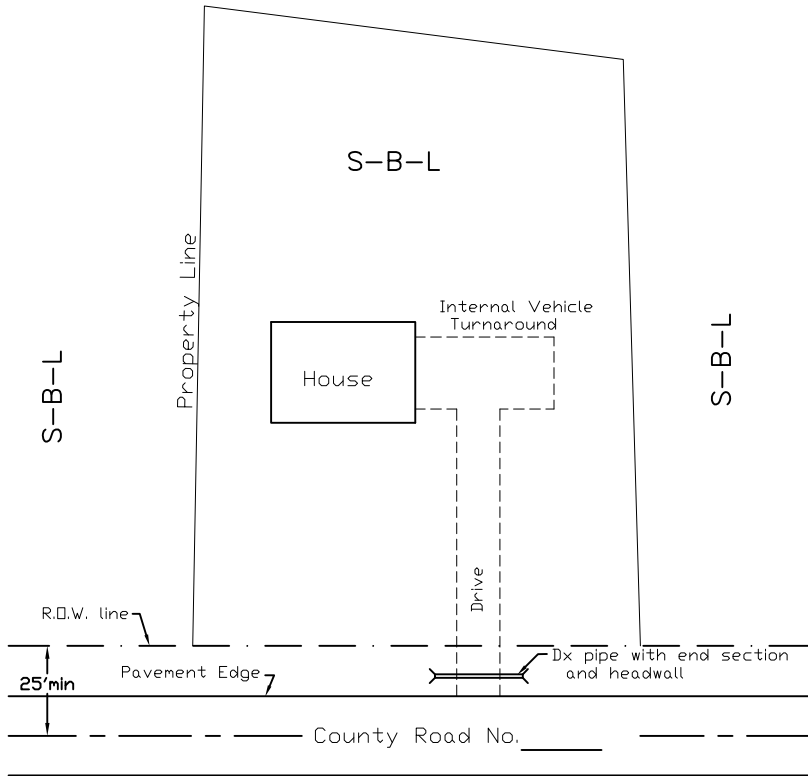

PLAN

Note: Show pipe size, grades, distances

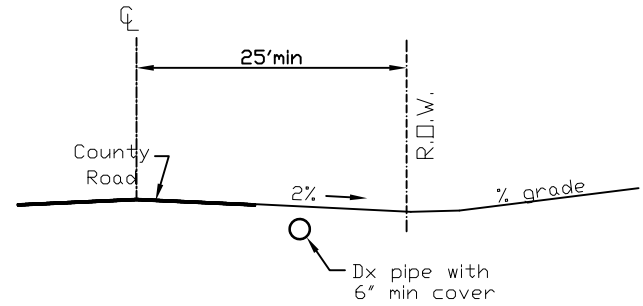

DRIVEWAY PROFILE

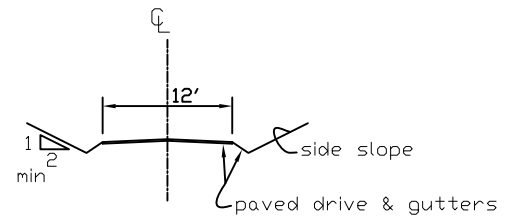

DRIVEWAY CROSS SECTION

Note: Show all data, materials, erosion control paving, gutters, etc.

ULSTER COUNTY DEPT. of PUBLIC WORKS

DRIVEWAY ENTRANCE DETAILS

Date: 5/21/2019

Scale: N.T.S.

DWG: 1

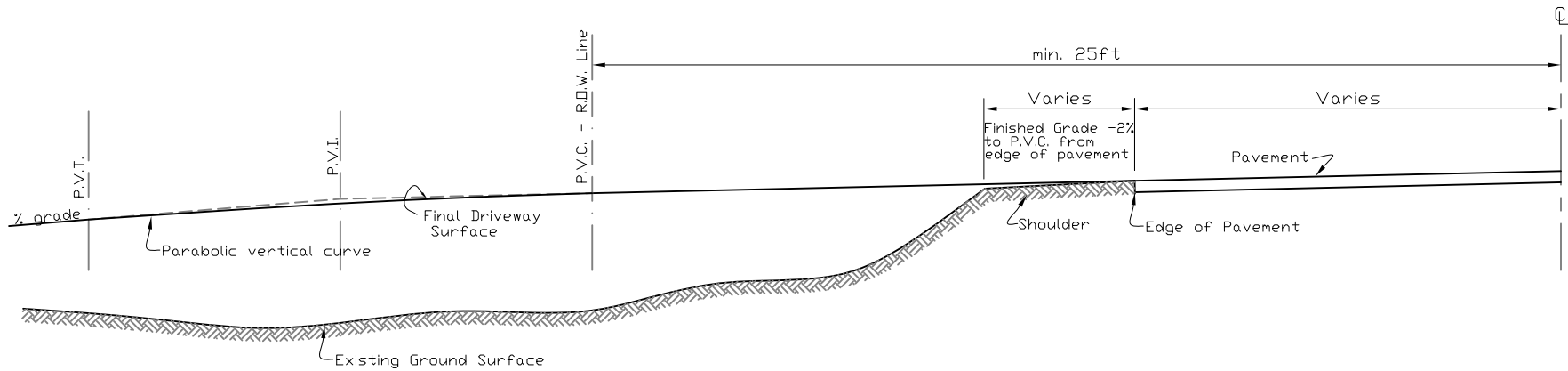

Note:

Drive shall be paved from edge of pavement to County Road R.D.W. line minimum or as directed by Ulster County Dept. of Public Works - Division of Engineering

SAMPLE

ULSTER COUNTY DEPT. of PUBLIC WORKS

TYPICAL EMBANKMENT SECTION

Date: 4/24/2015

Scale: N.T.S.

DWG: 2

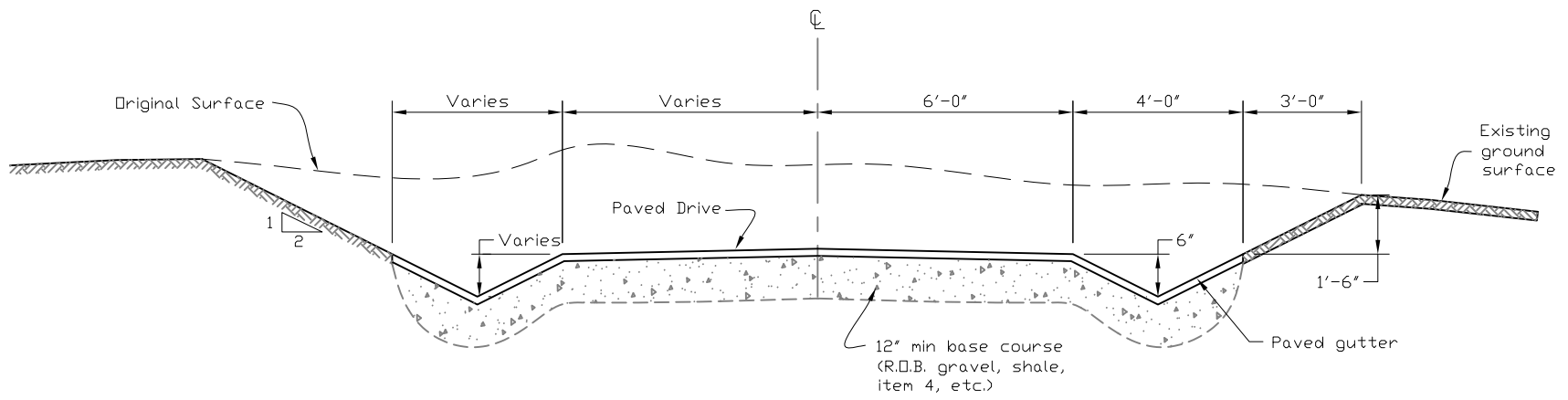

Note:
 Values shown on the right side of the section are
 examples only and do not reflect actual conditions

ULSTER COUNTY DEPT. of PUBLIC WORKS

TYPICAL CUT SECTION
 ENTRANCE CROSS-SECTION

Date: 4/24/2015

Scale: N.T.S.

DWG: 3

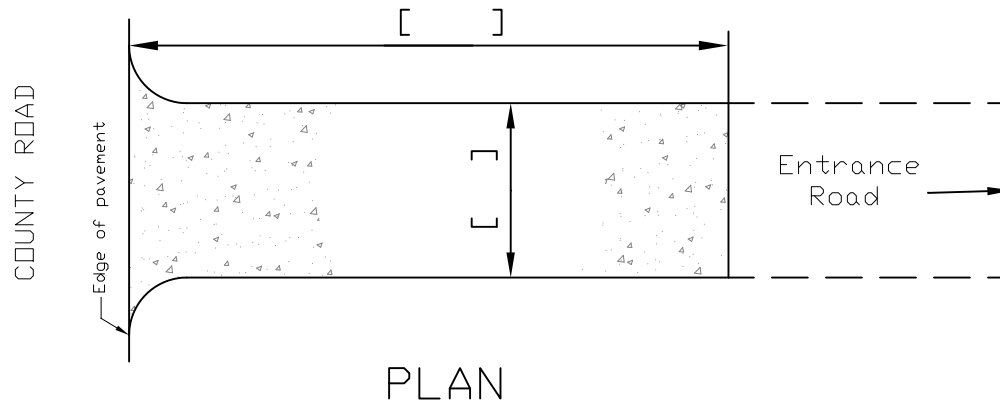

PLAN

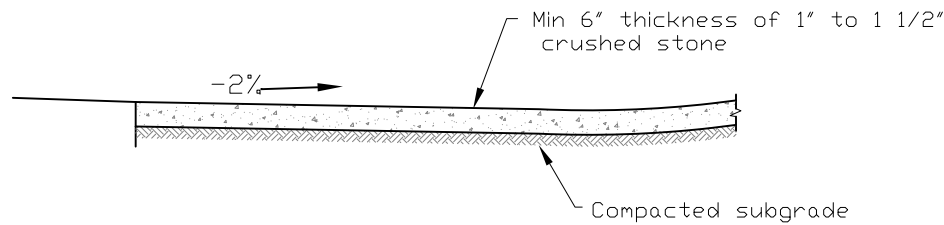

SECTION

Note: Entrance shall be maintained as conditions demand to prevent tracking of sediment onto the public right-of-way

- A crushed stone, vehicle, wheel cleaning blanket is to be installed whenever a construction access road intersects any paved roadway. Said blanket will be composed of a 6" depth of 1" to 1 1/2" crushed stone and will be at least 30' x 100' and is to be placed on compacted subgrade and shall be maintained.
- All driveways must be stabilized with 1" to 1 1/2" crushed stone or sub-base prior to individual home construction if directed by Ulster County D.P.W.
- Paved roadways must be kept clean at all times
- All catch basins are to be protected with a crushed stone or hay bale filter (filter details to appear on the plan)
- All storm drainage outlets will be stabilized, as required, before discharge points become operational.
- All soil erosion and sediment control structures must be detailed on the plan.

ULSTER COUNTY DEPT. of PUBLIC WORKS

STABILIZED CONSTRUCTION
ENTRANCE

Date: 4/24/2015

Scale: N.T.S.

DWG: 4

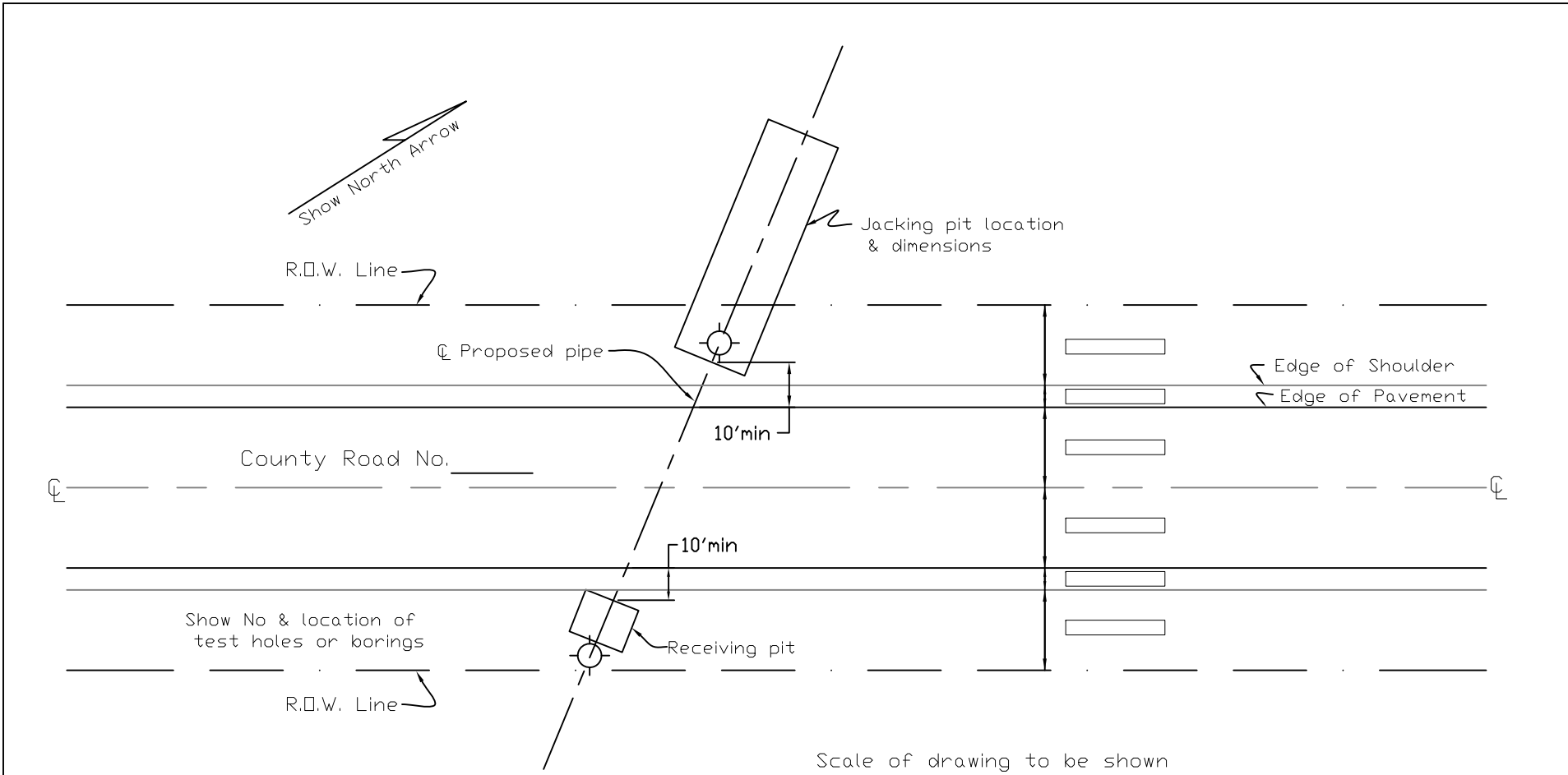

ULSTER COUNTY DEPT. of PUBLIC WORKS		
INFORMATION TO BE SHOWN ON PLAN SECTION FOR JACKING & BORING		
Date: 4/24/2015	Scale: N.T.S.	DWG: 5

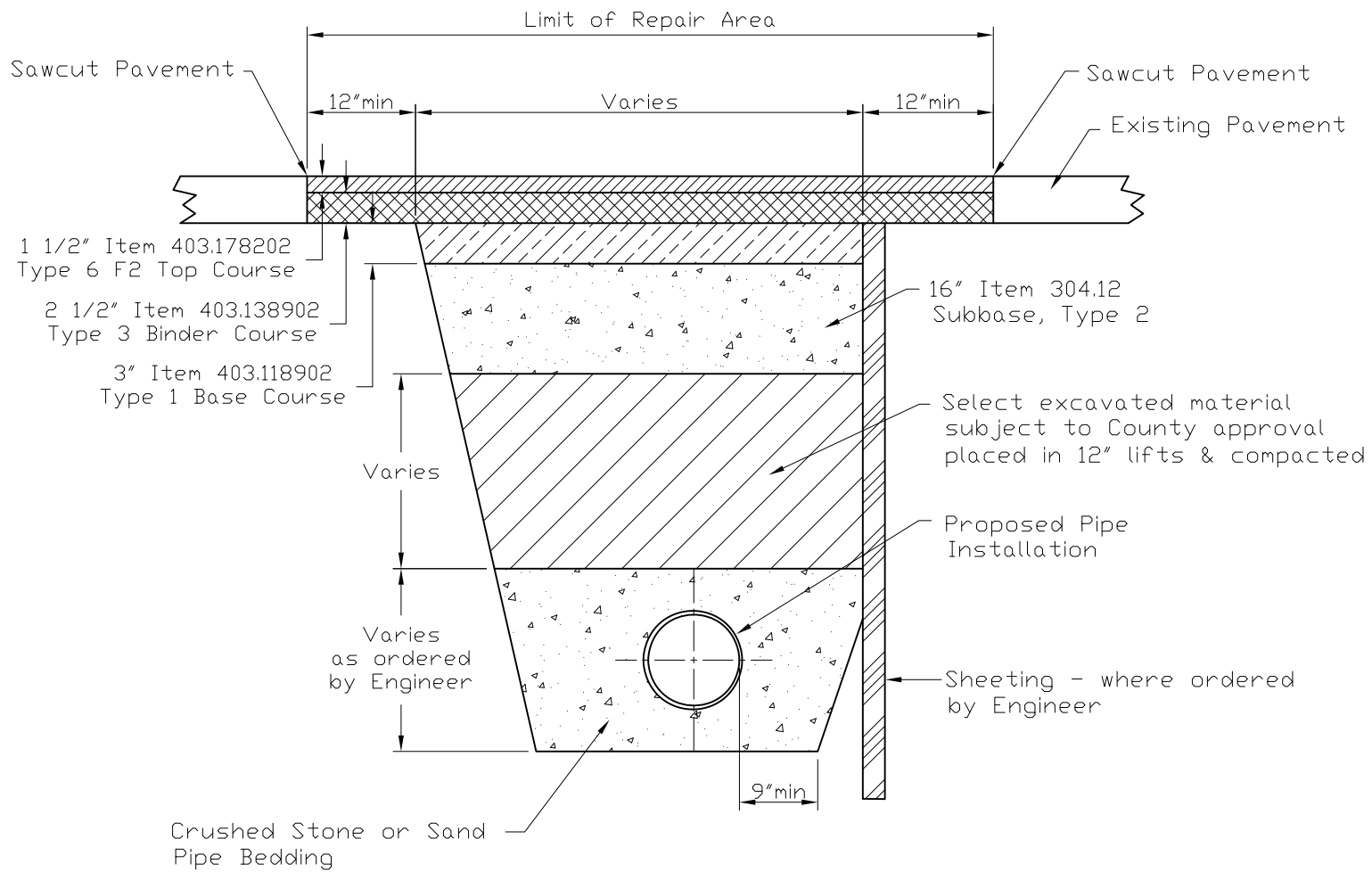

ULSTER COUNTY DEPT. of PUBLIC WORKS		
BACKFILL AND ROAD REPAIR DETAILS		
Date: 4/24/2015	Scale: N.T.S.	DWG: 6

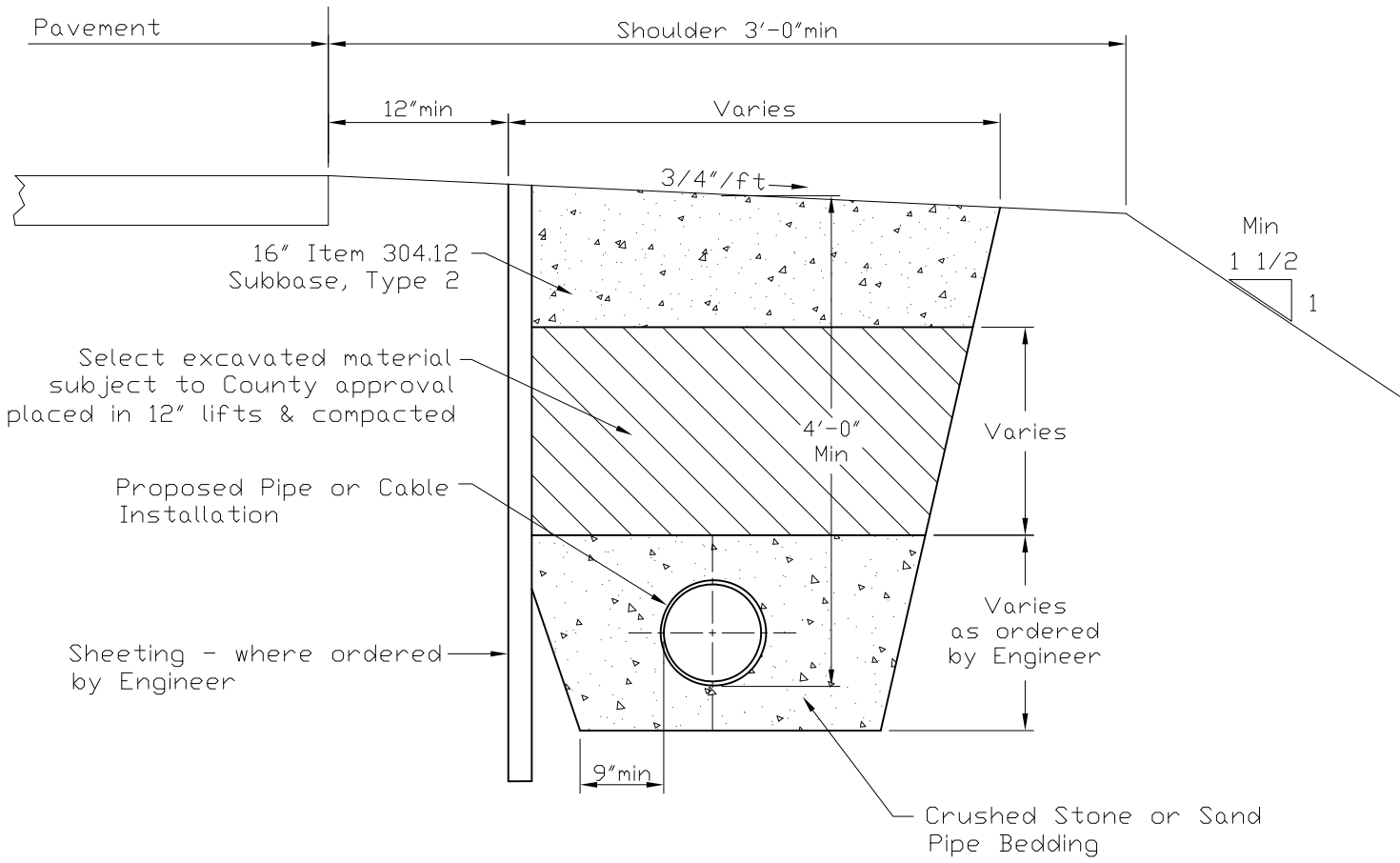

ULSTER COUNTY DEPT. of PUBLIC WORKS		
PIPE OR CABLE IN SHOULDER DETAILS		
Date: 4/24/2015	Scale: N.T.S.	DWG: 7

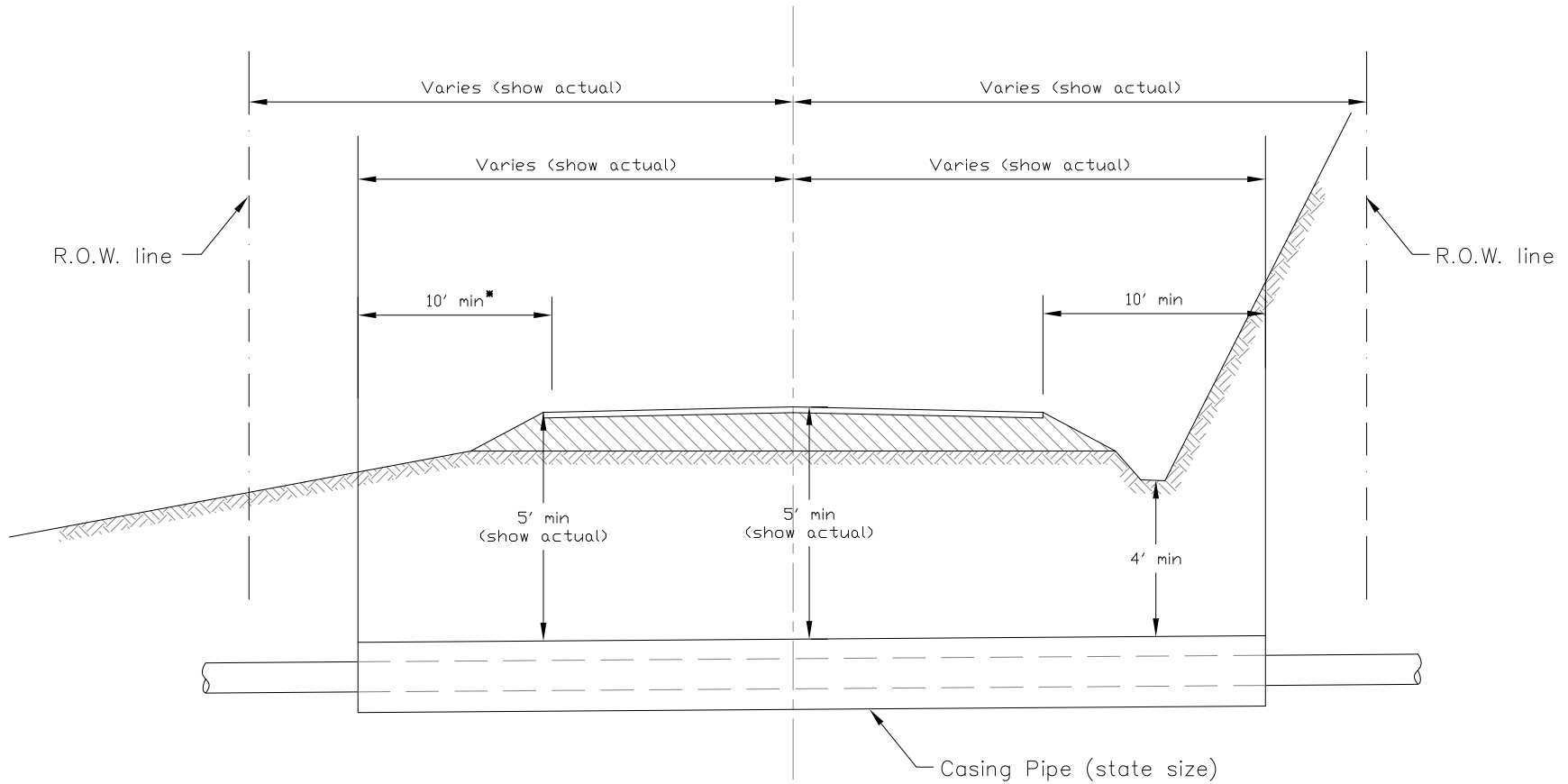

* For casing that is carrying flammable substances, this dimension shall be 25' min or to the R.O.W. line (whichever is greater)

SAMPLE

ULSTER COUNTY DEPT. of PUBLIC WORKS

CASING PIPE INSTALLATION

Date: 4/24/2015

Scale: N.T.S.

DWG: 8

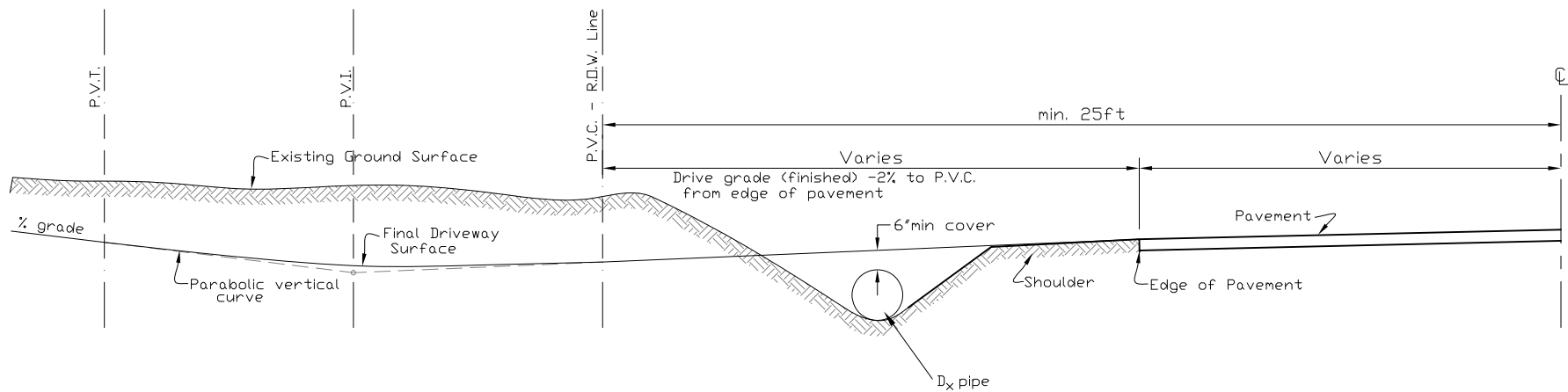

Note:

Drive shall be paved from edge of pavement to County Road R.O.W. line minimum or as directed by Ulster County Dept. of Public Works - Division of Engineering

SAMPLE

ULSTER COUNTY DEPT. of PUBLIC WORKS

TYPICAL CUT SECTION

Date: 4/24/2015

Scale: N.T.S.

DWG: 9

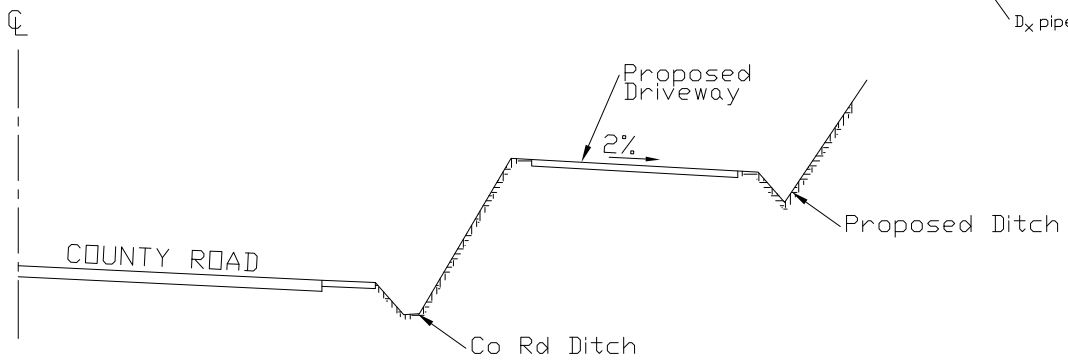
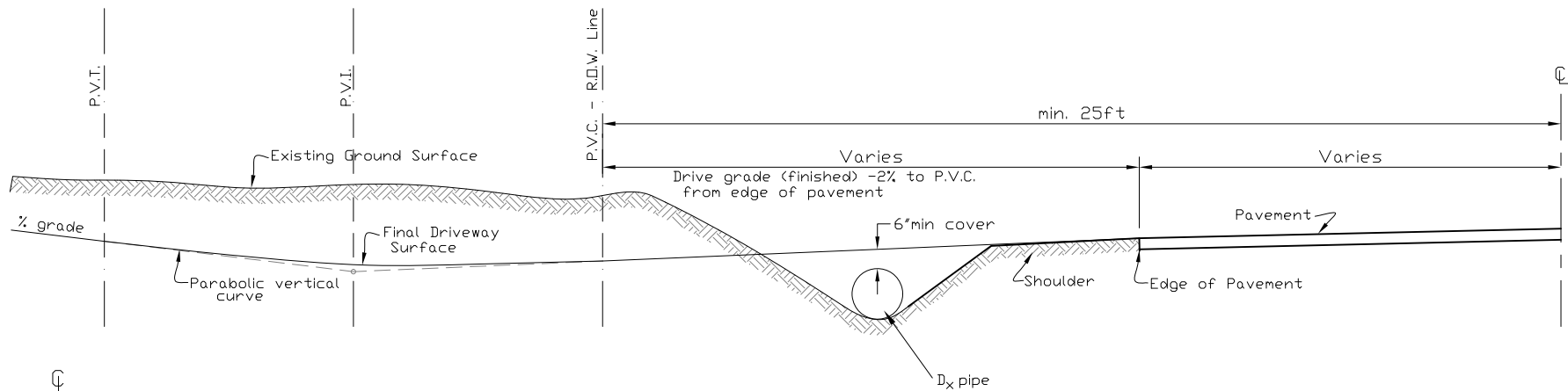

SECTION A-A

SAMPLE

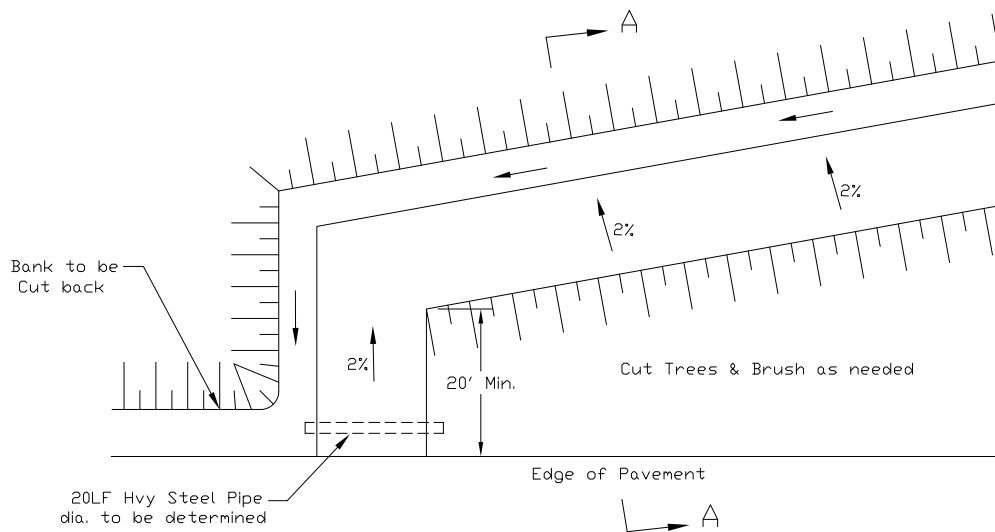

ULSTER COUNTY DEPT. of PUBLIC WORKS

TYPICAL CUT LAYOUT
AND DETAILS

Date: 4/24/2015

Scale: N.T.S.

DWG: 10